

SafeGuard Safety Systems  
**Elev8or**



**PROTECTING PERSONNEL  
FROM HAZARDS ASSOCIATED  
WITH WORKING IN AND  
AROUND WIND TURBINE  
SERVICE LIFTS AND  
MOVING ELEVATORS.**

[info@SGsafety.com](mailto:info@SGsafety.com) | [www.SGsafety.com](http://www.SGsafety.com)

Click to follow us on 

## SafeGuard Safety Systems

# Elev8or

**SafeGuard Safety Systems (SG) are designers and manufacturers of CE Certified safety products and systems which are created specifically to protect personnel against falls from height and dangers associated with machinery and equipment.**

In addition, SG products are designed and manufactured to provide our clients with the assurance that they are complying with applicable legislation and directives.

The SG **Elev8or** CE Certified range of products are designed to protect personnel working in and around wind turbine service lifts from hazards associated with moving elevators.

SG are both a designer and manufacturer. They supply products either to trained installers, through SG's installer network, or using the customers own staff or sub-contractors, who have been trained on the installation and commissioning of the product.

SG products can be installed in new turbines or retrofitted to existing turbines.

In either case, a full design risk assessment has been carried out to ensure that a hierarchical approach is adopted, leading to evaluated decisions being made on risk reduction measures and designs to integrate safety-related parts to control systems.

**The SG Elev8or range of products have the following distinct product categories:**

1. Guarding and Barriers
2. Interlocking
3. Emergency Stop and Protection Devices
4. Alert & Warning
5. Elevator Manufacturer Supplied Products

# Guarding and Barriers

**KeepSafe Guarding and SepR8or Barriers** are designed to be both compliant and compatible with the area in which it is they are to be installed.

SG design and manufacture bespoke solutions or can supply guarding and/or barriers designed and supplied by the wind turbine elevator manufacturer.

**KeepSafe** Guarding and **SepR8or** Barriers are designed to be both compliant and compatible with the area in which they are to be installed. Key stakeholders are involved in the design process to ensure there is no conflict with adjacent equipment or processes.

The SG **KeepSafe** range of guarding products are completely enclosed guarding solutions with inter-locked gates, designed to not only offer fall protection, but to prevent access to the liftway when there is danger presented from moving parts

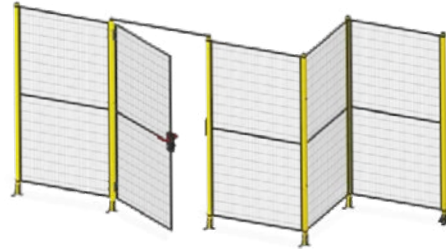

The SG **SepR8or** range of barriers, are for areas where there are limitations in place either due to available space to install a **KeepSafe** system, integration with lift design and functionality, or where the customer, wishes to install a barrier rather than full guarding. The **SepR8or** range can be upgraded to **KeepSafe** at any point in the future.

Guarding and barrier solutions can be provided in either a full or partially assembled 'kit' or 'single component' form depending on the location of the turbine (on or offshore), access throughout the turbine via hatches and walkways as well as the customer's specific needs.

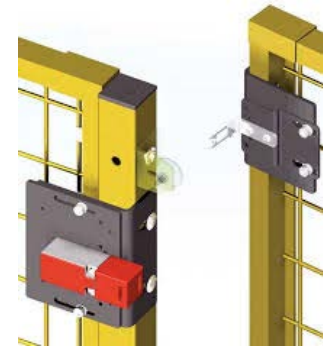

# Interlocking

SG Interlocking systems are supplied as part of a guarding system and can be either electrical or mechanical interlocking systems to ensure access to the elevator space can only be achieved when there is no danger present via moving parts.

# Emergency Stop and Protection Devices

**SG design and supply a range of emergency stop and protection devices.**



These can be installed outside of, and separate from the elevator, can be either automatically activated when personnel access the liftway, or manually activated by personnel, when a danger from a moving elevator is identified. This can be either at a specific point (s) within the tower or at any point throughout the elevator travel path.

SG can supply either own brand Emergency Stop and Protection Devices and / or service lift manufacturer supplied products. These and can be installed either as a standalone solution or as part of an SG designed system utilising products form different manufacturers.

## Alert & Warning

SG provide products that alert personnel to a moving elevator, either visibly or audibly or using a combined audible-flashing beacon.

## Elevator Manufacturer Supplied Products

SG work with service lift manufacturers to provide retrofit solutions, either using SG products, the elevator manufacturers products or a combination of both.

SG want wind turbine service lifts returned to normal use and their full design functionality.

SG believe in sustainability and pledge that they will plant a tree for every **Elev8or** system installed within a wind turbine as part of their corporate carbon offsetting policy.

## Question?

We ask all our customers the following questions.

Is it possible for personnel in the vicinity of a service lift to be:

- Struck by a moving service lift?
- Crushed/sheared by a moving service lift?
- Trapped in/by a moving service lift?
- Pulled into a moving service lift?
- Entangled in a moving service lift?

If you answered 'yes', then please contact SafeGuard:

[info@SGsafety.com](mailto:info@SGsafety.com)

Or contact your approved SG Safety Systems Installer:

*INSTALLER*

*CONTACT*

*PRODUCT APPROVAL*



Thank you for taking the time to  
read this information booklet.

For further information:

[info@SGsafety.com](mailto:info@SGsafety.com)

[www.SGsafety.com](http://www.SGsafety.com)



Click to follow us on 